



DKAMANS
VALVE



PBV Ball Valves
Severe Service Ball Valves

REQUEST A QUOTE
sales@dkamans.com

SCHEDULE SERVICES
562-529-8400

WWW.DKAMANS.COM

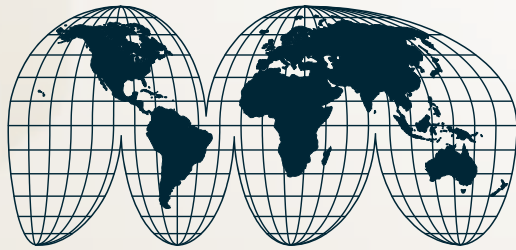

Manufacturer of Quality Valve Products Around the Globe

At Forum™ Energy Technologies we are committed to improving our clients' operational and financial performance by supplying the most comprehensive range of valve products in the industry through our family of trusted valve brands.



Engineering Expertise

Forum™ utilizes the latest state of the art engineering software to provide custom design services. Finite element analysis is just one of many Design Verification Tools FET uses for designing valves to specific customer requirements.



Manufacturing and Construction

All PBV® valves are manufactured of the highest quality materials with state-of-the-art CNC machines to assure critical accuracy required for high performance zero-leakage metal seated ball valve construction. PBV® match laps all balls and seat surfaces for bubble tight sealing, plus all universal mounting brackets are machined to ISO standards.



Quality Control

All FET Companies manufacture quality products that are designed and tested to meet the stringent standards of most Qualifying Authorities around the world. Advanced Engineering and our

Quality Management System assure that our valve products continue to exceed your expectations.



Compliance and Testing

All PBV® ball valves are manufactured and tested to comply with many international qualifying authorities as well as our own strict quality control procedures. Many procedures exceed MSS-SP61, API-598, API-607, API-608 and ANSI FCI 70.2 Class VI.

All testing procedures comply with ANSI B16.34 and testing can be summarized as follows:

- Hydrostatic: 1.5 x max. CWP. Zero Leakage/60 seconds.
- High Pressure Seat: 1.1 x max. CWP. Zero Leakage/60 seconds.
- Low Pressure Seat: 50 psi. Zero Leakage/60 seconds.
- Additional, Air: 50 psi. Zero Leakage/60 seconds.



Customer Service

Forum™'s Customer Service Departments are fully staffed with trained customer service representatives ready to help you with your order information, technical specifications and project logistics.

PBV® Severe Service Ball Valve Certification

PBV® meets or exceeds all requirements for ISO 9001:2008 certification and also implements their own stringent testing and quality assurance program requirements to meet the exacting standards of the industry's leading authorities and your specific application requirements. Contact your PBV® representative for more information.

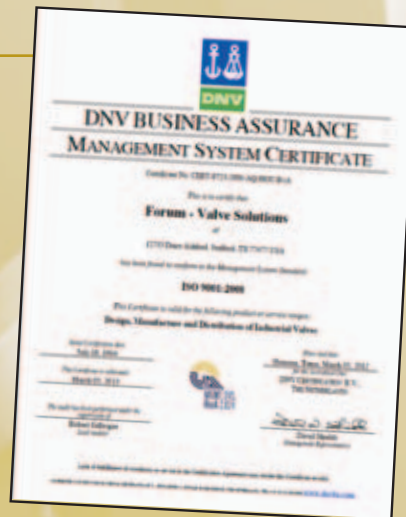

Contents

PBV® Severe Service Ball Valves

Introduction & How To Order 3

Series Z1 Unibody Power Valve
Features, Applications, Dimensional Data, Parts & Materials ... 4-5

Series Z2 Two-Piece Industrial Valve
Features, Applications, Dimensional Data, Parts & Materials ... 6-8

PRV Pressure Relief Valve
Features & Applications 9

Series Z1 & Z2 Engineering Data
Flow Coefficient (C_v) & Nominal Pipe Size 10-11

PBV® Severe Service Ball Valve Solutions

PBV® Series Z1 & Z2 One and Two-Piece Metal Seated Severe Service Ball Valves and PRV Pressure Relief Valve

PBV® introduces their NEW Series of Severe Service Ball Valves engineered for zero-leakage and critical applications.

When it comes to media leakage and critical isolation, now you can strike back with PBV®'s superior quality, long lasting, low maintenance metal seated ball valve solution.

Z1 Series Unibody High-Pressure Severe Service Ball Valve



Z2 Series Two-Piece Metal Seated Severe Service Ball Valve



PRV Pressure Relief Valve



Specifying PBV® Metal Seated Severe Service Valve Figure Numbers

Example: 2.5 x 2 Z125-2240C-99-G418 This number represents a 2.5" NPS x 2" Bore Series Z1 One-Piece Power Valve in ANSI Class 2500, with F22 Body Material and 410SS Ball and Seat Material Coated with HVOF Chromium Carbide, SWE Upstream End Connection and a SWE Downstream End Connection, equipped with Gear Operator and 4" Tall Mounting Bracket with an ISO F10 Mounting Pattern and a 36 mm Coupler.

2.5 x 2 Z1 25 - 22 40 C - 9 9 - G 4 1 8

Bore Size (in.)		Series	ANSI Class	Body Material	Ball & Seat Material	Ball & Seat Coating	Upstream End Conn.	Downstream End Conn.	Operator	Bracket Height	ISO 5211 Mounting Pattern	Coupler Size
Z1*	Z2**											
.65	1/2	Z1	10	05	36	C	1	1	A	4	0	6
1	3/4	1-PC Power Valve	150 CL	A105	316SS	HVOF Chromium Carbide	Raised Face Flange	Raised Face Flange	Actuator	4"	F07	22 mm
1.4	1	Z1-H	30	22	40	T	3	3	B	6	1	7
1.75	1 1/2	Half Long Body	300 CL	F22	410SS	HVOF Chromium Carbide	RTJ	RTJ	Bare Stem	6"	F10	27 mm
2	2	Z1-SB	60	91	43	S	5	5	(Specify Bracket & Mntg. Pad)	8	2	8
2.5	3	1-PC Soot Blower	600 CL	F91	431SS	HVOF Chromium Carbide	BWE (Specify Pipe Schedule)	BWE (Specify Pipe Schedule)	(Specify Bracket & Mntg. Pad)	8	F12	36 mm
3	4	Z2-FPU	90	36	44	X	8	8	G	12	3	9
	6	2-PC Full Port Uni-Direction.	900 CL	316	17-4SS	Stellite®	(Specify Pipe Schedule)	(Specify Pipe Schedule)	Gear	16	4	K
	8	Z2-FPB	15	04	51	S	8	8	L	16	4	K
	10	2-PC Full Port Uni-Direction.	1500 CL	Steel	F51 Duplex	Stellite®	NPT	NPT	Lever	16"	F16	Keyed
	12	Z2-RPU	25	04	55	X	9	9	L	X	5	SP
	14	2-PC Full Port Bi-Directional	2500 CL	304	F55 Duplex	Special	SWE	SWE	Lever	Special	F25	Special
	16	Z2-FPB	32	51	71	S						
	18	2-PC Full Port Bi-Directional	3200 CL	Steel	Monel®	HVOF Chromium Carbide						
	20	Z2-RPU	35	F51	73	S						
	24	2-PC Red. Port Uni-Direction.	3500 CL	F51 Duplex	Hastelloy® C	HVOF Chromium Carbide						
		Z2-RPU	45	55	74	S						
		2-PC Red. Port Uni-Direction.	4500 CL	F55 Duplex	Inconel®	HVOF Chromium Carbide						
		Z2-RPB		SP	75	S						
		2-PC Red. Port Bi-Directional		Special	Inconel®	HVOF Chromium Carbide						
		Z3-PRV		09	SP	S						
		Pressure Relief Valve		F9	Special	HVOF Chromium Carbide						

Note: *When placing orders please include NPS x Bore size before "Series" number. **Z2 Valves are available in Full Port and Reduced Port configurations.

PBV® Z1 Unibody Power Valve

Features, Applications & Dimensional Data

PBV® Z1

One-Piece metal seated ball valves for high-pressure severe service applications including Power Generation and critical on/off applications.

- .65" - 3" Bore Size
- 150 - 4500 ANSI Class
- Design Meets ASME TDP-1 2006 Bore Requirements
- 1/2" - 4" Nominal Pipe Size
- 4 Year Warranty
- Materials: A105, F22, F91 and 316SS

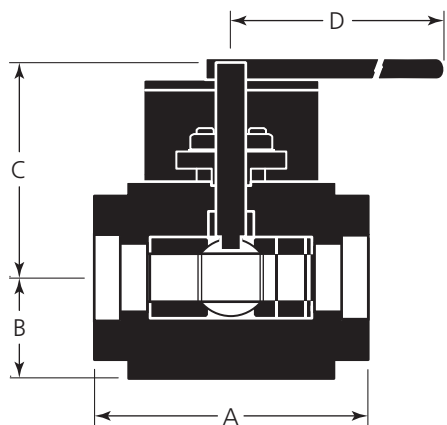
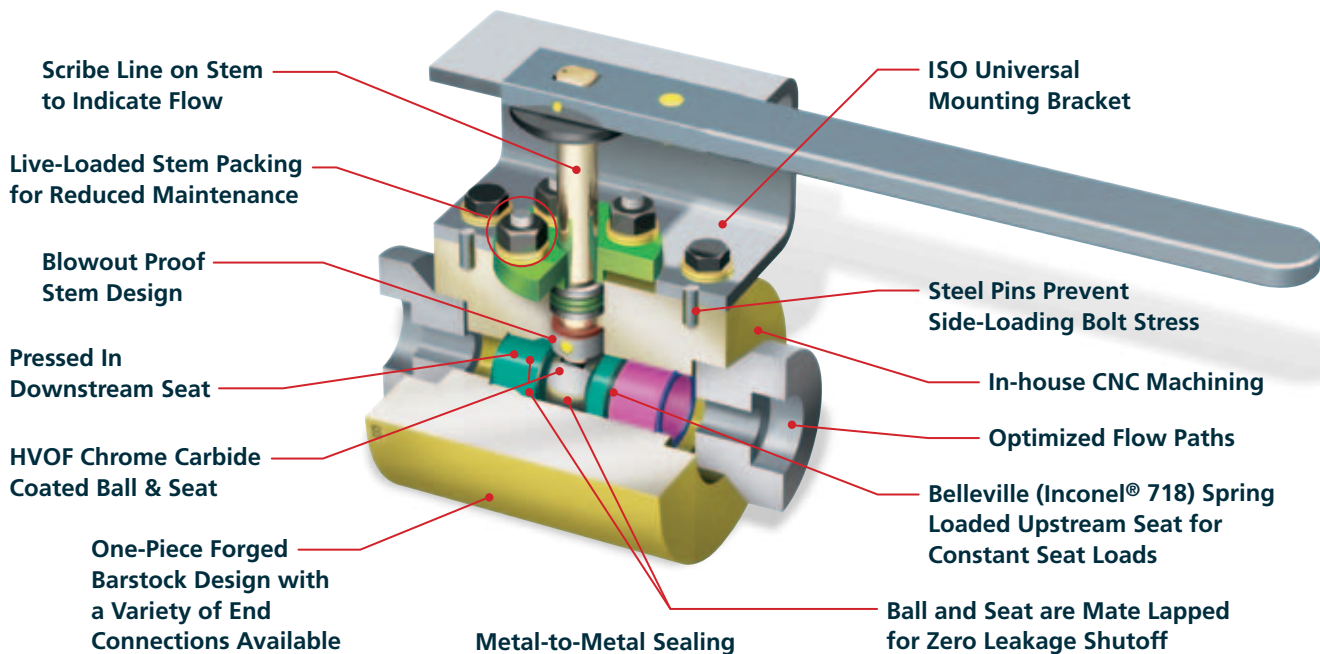

End Configuration Dimensions
NOTE: From Centerline of Valve.

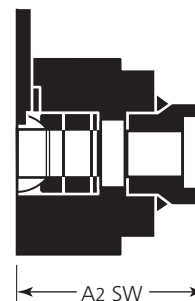
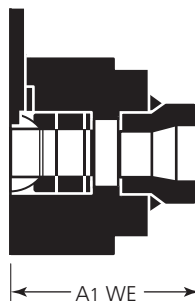

Dimensional Data

Bore Size (in.)*	A	A1 WE	A2 SW	B	C	D	Weight (lbs.)
.65	5.00	4.50	3.50	2.25	5.00	13.25	25
1.00	6.00	5.00	4.00	2.75	5.50	19.25	46
1.40	8.00	6.00	5.50	3.00	5.75	19.25	66
1.75	9.50	7.25	6.25	3.25	6.00	24.00	98
2.00	12.25	8.13	6.25	4.25	7.75	NA	170
2.50	14.00	**	9.50	5.50	10.50	NA	**
3.00	14.50	**	9.00	5.25	11.00	NA	**

Note: * .65" & 1" Bore: 1" NPS SW & smaller use A2. 1.5" NPS SW & larger use A.
1.4" Bore: 1.5" NPS SW & smaller use A2. 2" NPS SW & 2.5" NPS SW use A.
1.75" Bore & larger, consult factory.

** Consult factory for dimensions and weights not listed.

Dependable Performance for All of Your Power Applications

PBV®'s Series Z1 Metal Seated Severe Service Ball Valve is designed for dependable zero leakage performance in high pressure, high temperature, clean critical steam applications.

PBV® offers the Z1 Severe Service Ball Valve in a variety of sizes and materials to meet your specific application requirements. Contact your PBV® Representative today for more information about PBV® Severe Service Ball Valves.

PBV® Z1 Unibody Power Valve

Parts & Materials

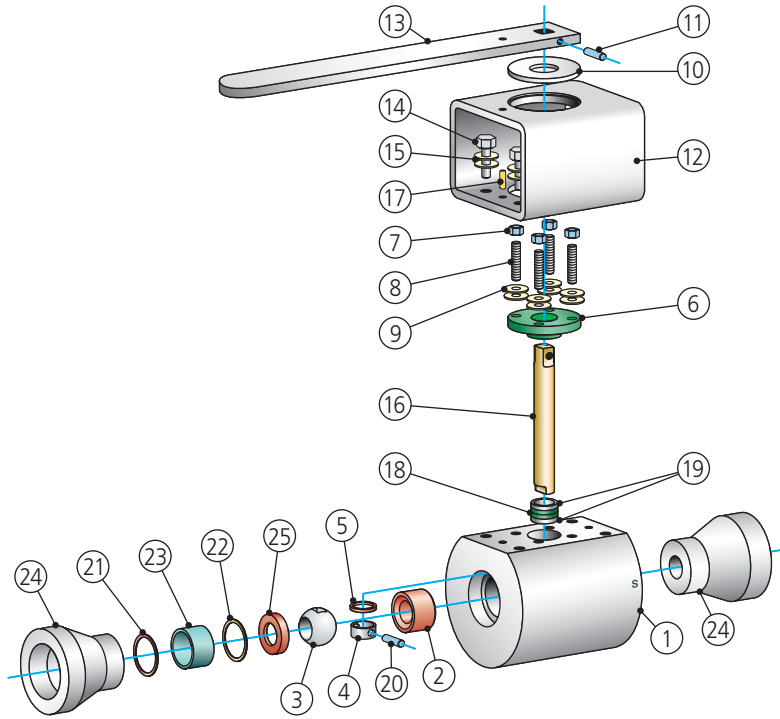

Pinned ISO Mounting Bracket Prevents Stem Side-Loading and Bolt Stress.

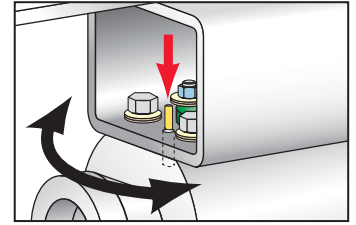

Live-Loading Belleville Washers Provide Constant Packing Pressure to Insure a Tight Seal.

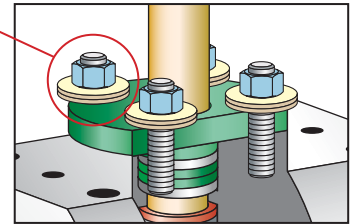

Packing Consists of Two GTP Graphite Rings Sandwiched Between Graphite Inconel® Anti-Extrusion Packing Rings.

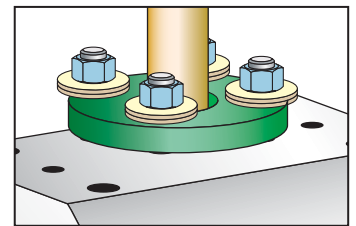

4-Bolt Packing Gland Flange is Properly Spaced for Easy Access with Commercial Tools.

Parts & Materials

Size	Qty.	Description	Material			
			A105/LF2	A182 F22	A182 F91	A182 F316
1	1	Body	A105	A182 F22	A182 F91	A182 F316
2	1	Seal Seat	410SS/CCC	410SS/CCC	410SS/CCC	410SS/CCC
3	1	Ball	410SS/CCC	410SS/CCC	410SS/CCC	410SS/CCC
4	1	Stem Collar	410SS/QPQ	410SS/QPQ	410SS/QPQ	410SS/QPQ
5	1	Stem Bearing	410SS/QPQ	410SS/QPQ	410SS/QPQ	410SS/QPQ
6	1	Gland	410SS	410SS	410SS	410SS
7	1	Gland Nut	A193-B8M	A193-B8M	A193-B8M	A193-B8M
8	1	Gland Stud	A194-GR8	A194-GR8	A194-GR8	A194-GR8
9	1	Live-Loaded Spring	300SS	300SS	300SS	300SS
10	1	Adapter Bushing	Cast Iron	Cast Iron	Cast Iron	Cast Iron
11	1	Shear Pin	Carbon Steel	Carbon Steel	Carbon Steel	Carbon Steel
12	1	Mounting Bracket	CS ASTM A-500	CS ASTM A-500	CS ASTM A-500	CS ASTM A-500
13	1	Hand Lever	Carbon Steel	Carbon Steel	Carbon Steel	Carbon Steel
14	1	Hex Head Screw	J429 GR5	J429 GR5	J429 GR5	J429 GR5
15	1	Washer	Carbon Steel	Carbon Steel	Carbon Steel	Carbon Steel
16	1	Stem	A638 GR660	A638 GR660	A638 GR660	A638 GR660
17	1	Pin	Carbon Steel	Carbon Steel	Carbon Steel	Carbon Steel
18	1	Stem Packing	Grafoil®	Grafoil®	Grafoil®	Grafoil®
19	1	Stem Packing (Anti-Extrusion)	Grafoil®/Inconel®	Grafoil®/Inconel®	Grafoil®/Inconel®	Grafoil®/Inconel®
20	1	Load Pin	Inconel® 718	Inconel® 718	Inconel® 718	Inconel® 718
21	1	Retaining Ring	ASTM A286 GR660	ASTM A286 GR660	ASTM A286 GR660	ASTM A286 GR660
22	1	Spring	Inconel® 718	Inconel® 718	Inconel® 718	Inconel® 718
23	1	Transition Spacer	Carbon Steel	Carbon Steel	Carbon Steel	Carbon Steel
24	1	Socketweld Adapter	A105	A182 F22	A182 F91	A182 F316
25	1	Seat Pusher	410SS/QPQ	410SS/QPQ	410SS/QPQ	410SS/QPQ

Note: Trim is Inconel® 718 on Class 4500 valves.
We reserve the right to change materials and specifications.

PBV® Z2 Two-Piece Industrial Valve

Features, Applications & Dimensional Data (Class 150)

PBV® Z2

Two-Piece metal seated ball valves for severe service applications including Chemical, Petro-Chemical, Abrasives, etc.

- 1/2" - 24" Nominal Pipe Size
- Available in SW, BW, FLF, RTJ, Hub and NPT Ends
- 150 - 2500 ANSI Class
- Materials: A105, F22, F91, 316SS and Others Upon Request
- Standard and Full Port
- Uni or Bi-directional

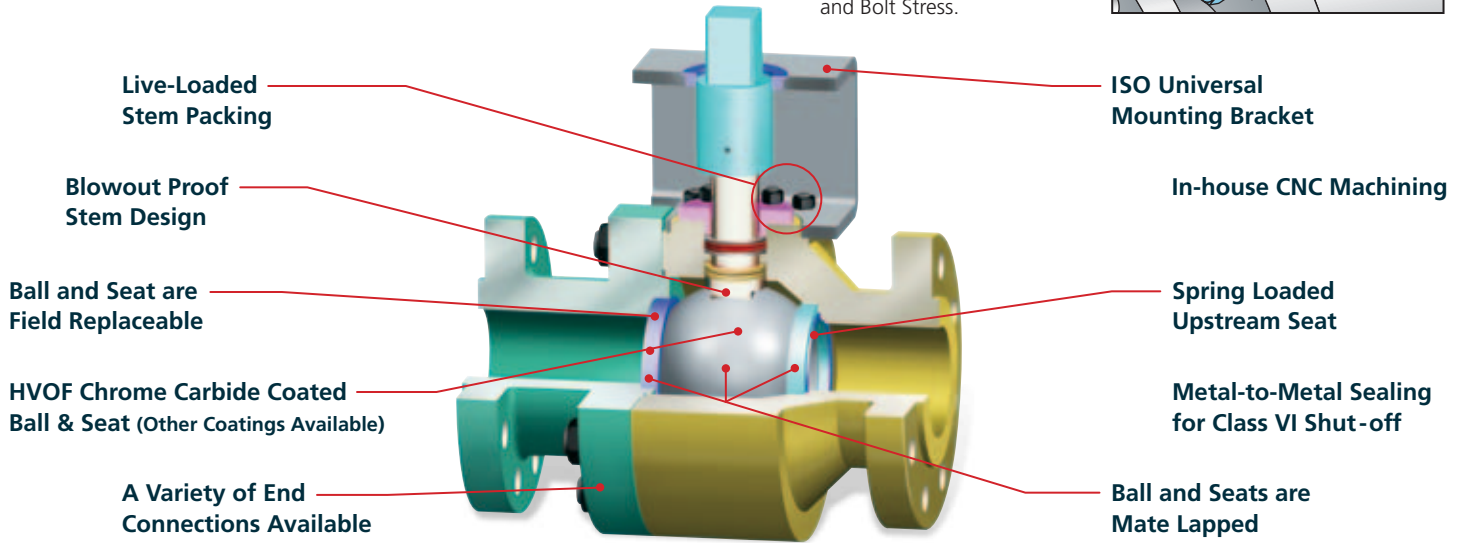
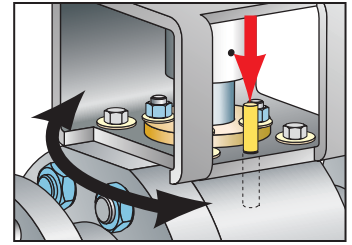

Rugged Design for All of Your Industrial Applications

PBV®'s Series Z2 Metal Seated Severe Service Ball Valve is designed for dependable performance in critical service industrial applications including Oil & Gas Refining, Petroleum & Petro-Chemical Production and many others.

PBV® offers the Z2 Severe Service Ball Valve in a variety of sizes and materials to meet your specific application requirements. Contact your PBV® Representative today for more information about PBV® Severe Service Ball Valves.

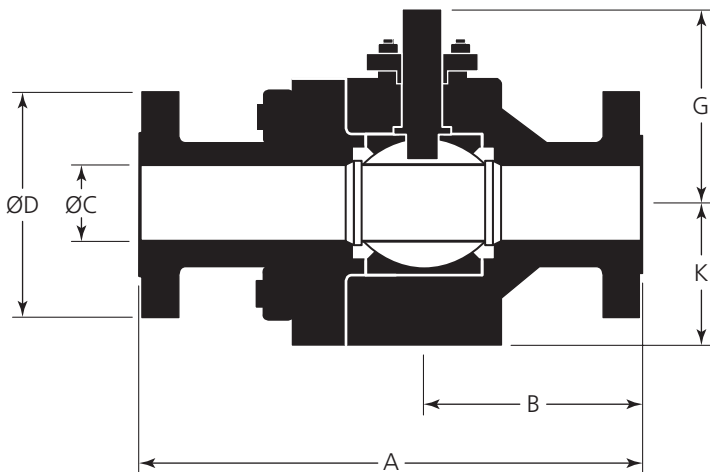

Class 150 Dimensional Data

Size (in.)	A	B	ØC	ØD	G	K
1/2	4.25	2.00	0.50	3.50	2.75	2.38
3/4	4.62	2.38	0.75	3.88	3.00	2.50
1	5.00	2.63	1.00	4.25	4.88	3.00
1 1/2	6.50	2.88	1.50	5.00	5.25	3.13
2	7.00	3.25	2.00	6.00	6.00	3.38
3	8.00	4.00	3.00	7.50	7.00	4.50
4	9.00	3.75	4.00	9.00	8.25	5.00
6	15.50	7.50	6.00	11.00	11.50	7.75
8	18.00	9.25	8.00	13.50	15.00	9.50
10	21.00	10.75	10.00	16.00	17.75	11.50
12	24.00	12.00	12.00	19.00	19.00	12.25
14	27.00	13.50	13.25	21.00	21.50	14.50
16	30.00	15.00	15.25	23.50	22.00	15.50
18	34.00	17.00	17.25	25.00	30.00	17.50
20	36.00	18.00	19.25	27.50	34.00	21.00
24	42.00	22.00	23.25	32.00	40.00	25.00

Note: Z2 Sizes are estimated.
Contact factory for verification when ordering.

PBV® Z2 Two-Piece Industrial Valve

Dimensional Data (Class 300, 600, 900, 1500 & 2500)

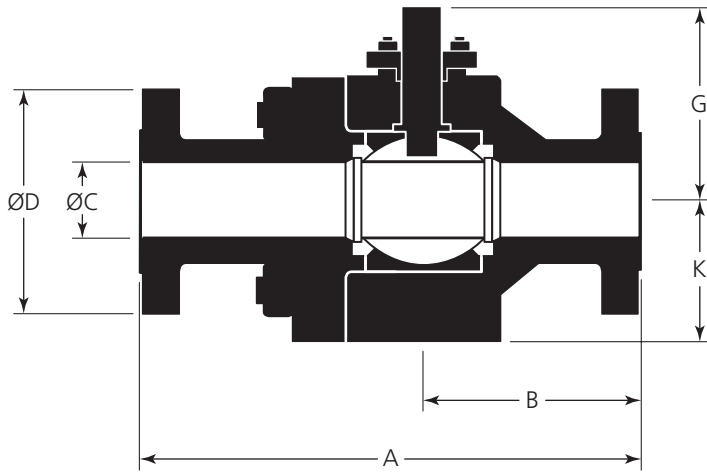

Class 300 Dimensional Data

Size (in.)	A	B	ØC	ØD	G	K
1/2	5.50	2.25	0.50	3.75	2.75	2.38
3/4	6.00	2.50	0.75	4.62	3.00	2.50
1	6.50	2.75	1.00	4.88	4.88	3.00
1 1/2	7.50	3.00	1.50	6.12	5.25	3.13
2	8.50	3.75	2.00	6.50	6.00	3.38
3	11.12	4.75	3.00	8.25	7.00	4.50
4	12.00	5.38	4.00	10.00	8.25	5.00
6	15.88	7.75	6.00	12.50	11.50	7.75
8	19.75	9.25	8.00	15.00	15.00	9.50
10	22.38	12.00	10.00	17.50	17.75	11.50
12	25.50	13.00	12.00	20.50	19.00	12.25
14	30.00	16.00	13.25	23.00	21.50	15.25
16	33.00	16.50	15.25	25.50	24.50	15.50
18	36.00	18.00	17.00	28.00	30.00	17.50
20	39.00	20.00	19.00	30.50	37.00	21.00
24	45.00	23.00	23.00	36.00	42.00	25.00

Class 600 Dimensional Data

Size (in.)	A	B	ØC	ØD	G	K
1/2	6.50	2.75	0.50	3.75	2.75	2.38
3/4	7.50	3.50	0.75	4.62	3.00	2.50
1	8.50	4.25	1.00	4.88	3.00	3.00
1 1/2	9.50	4.75	1.50	6.12	5.25	3.50
2	11.50	5.00	2.00	6.50	6.00	3.75
3	14.00	6.00	3.00	8.25	7.00	4.75
4	17.00	7.75	4.00	10.75	8.25	5.00
6	22.00	9.00	6.00	14.00	11.50	8.00
8	26.00	12.25	7.87	16.50	15.88	10.25
10	31.00	14.00	9.75	20.00	18.00	11.50
12	33.00	16.00	11.75	22.00	20.00	12.25
14	35.00	17.50	12.87	23.75	24.00	16.00
16	39.00	20.25	14.75	27.00	26.00	16.00
18	43.00	22.50	16.50	29.25	32.00	18.00
20	47.00	23.75	18.25	32.00	38.00	21.00
24	55.00	28.00	22.00	37.00	44.00	25.00

Class 900 Dimensional Data

Size (in.)	A	B	ØC	ØD	G	K
1/2	9.00	4.50	0.50	4.75	2.75	3.00
3/4	9.00	4.50	0.69	5.12	3.00	3.00
1	10.00	5.00	0.87	5.88	4.88	3.00
1 1/2	12.00	6.00	1.37	7.00	5.25	4.31
2	14.50	6.50	1.87	8.50	6.00	4.50
3	15.00	7.00	2.87	9.50	7.00	5.00
4	18.00	7.50	3.87	11.50	8.25	6.75
6	24.00	9.50	5.75	15.00	11.50	9.00
8	29.00	14.00	7.50	18.50	15.00	11.50
10	33.00	16.00	9.37	21.50	17.75	13.75
12	38.00	18.00	11.12	24.00	19.00	15.50

Class 1500 Dimensional Data

Size (in.)	A	B	ØC	ØD	G	K
1/2	9.00	4.50	0.50	4.75	4.75	3.00
3/4	9.00	4.50	0.69	5.12	4.75	3.00
1	10.00	5.00	0.87	5.88	4.75	3.00
1 1/2	12.00	6.00	1.37	7.00	7.50	3.50
2	14.50	6.50	1.87	8.50	8.25	4.38
3	18.50	8.50	2.75	10.50	9.50	5.50
4	21.50	9.75	3.62	12.25	12.13	7.25
6	27.75	11.00	5.37	15.50	17.50	10.00
8	32.75	14.00	7.00	19.00	20.00	12.50
10	39.00	16.00	8.75	23.00	21.00	15.50
12	44.50	19.00	10.37	26.50	24.00	14.00

Class 2500 Dimensional Data

Size (in.)	A	B	ØC	ØD	G	K
1/2	9.00	4.50	0.44	5.25	4.75	3.00
3/4	9.00	4.50	0.56	5.50	4.75	3.00
1	10.00	5.00	0.75	6.25	4.75	3.00
1 1/2	12.00	6.00	1.12	8.00	7.00	4.50
2	17.75	7.25	1.50	9.25	9.00	6.00
3	22.75	10.00	2.25	12.00	11.75	8.50
4	26.50	11.00	2.87	14.00	13.25	7.50
6	36.00	13.00	4.37	19.00	15.00	11.00
8	40.25	14.50	5.75	21.75	24.00	13.00
10	50.00	19.00	7.25	26.50	26.00	13.50
12	56.00	22.00	8.62	30.00	28.00	18.50

Note: Z2 Sizes are estimated. Contact factory for verification when ordering.
 Sizes 14" - 24" are available upon request.

PBV® Z2 Two-Piece Industrial Valve

Parts & Materials

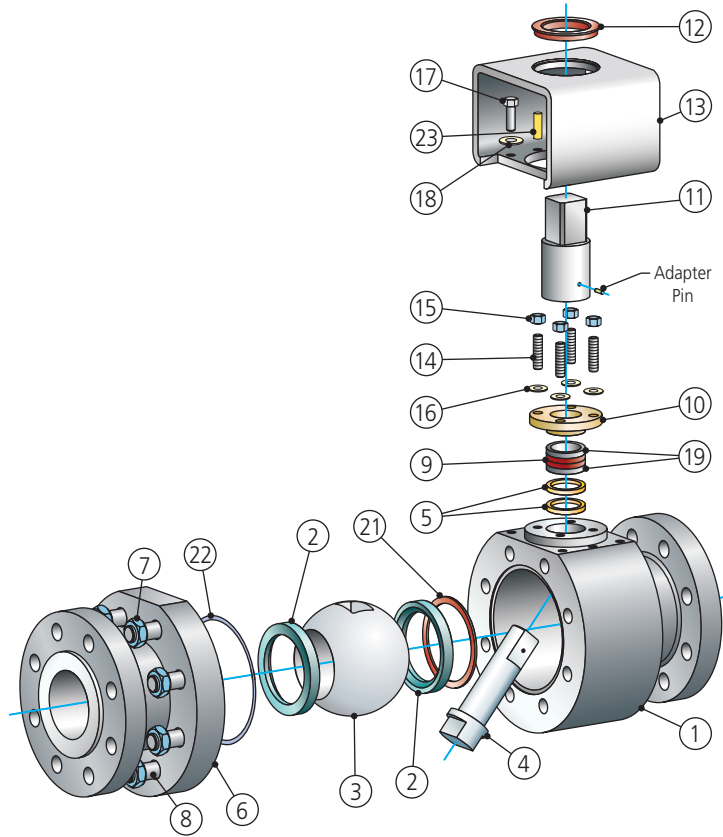

Pinned ISO Mounting Bracket Prevents Stem Side-Loading and Bolt Stress.

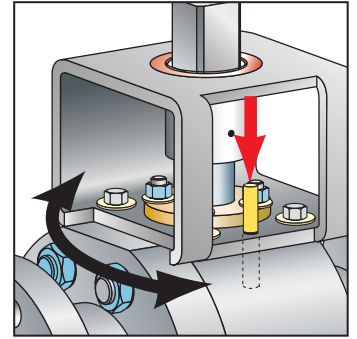

Packing Consists of Two GTP Graphite Rings Sandwiched Between Graphite Inconel® Anti-Extrusion Packing Rings.

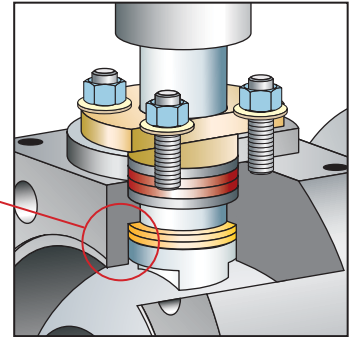

Coated Stem Bearing to Reduce Stem Torque

Parts & Materials

Size	Qty.	Description	Material			
			A105/LF2	A182 F22	A182 F91	A182 F316
1	1	Body	A105	A182 F22	A182 F91	A182 F316
2	2	Seal Seat	410SS/CCC	410SS/CCC	410SS/CCC	410SS/CCC
3	1	Ball	410SS/CCC	410SS/CCC	410SS/CCC	410SS/CCC
4	1	Stem	A638 GR660	A638 GR660	A638 GR660	A638 GR660
5	1	Stem Bearing	410SS/QPQ	410SS/QPQ	410SS/QPQ	410SS/QPQ
6	1	End Connection	A105	A105	A105	A105
7	1	Body Nut	ASTM A194-GR2H	ASTM A194-GR4H	ASTM A194-GR4H	ASTM A194-GR8
8	1	Body Stud	ASTM A193-B7	ASTM A193-B16	ASTM A193-B16	ASTM A193-B8
9	1	Stem Packing	Grafoil®	Grafoil®	Grafoil®	Grafoil®
10	1	Gland Flange	410SS	410SS	410SS	410SS
11	1	Stem Adapter	4140 HT	4140 HT	4140 HT	4140 HT
12	1	Adapter Bushing	Cast Iron	Cast Iron	Cast Iron	Cast Iron
13	1	Mounting Bracket	CS ASTM A-500	CS ASTM A-500	CS ASTM A-500	CS ASTM A-500
14	1	Gland Stud	A193-B8M	A193-B8M	A193-B8M	A193-B8M
15	1	Gland Nut	A194-GR8	A194-GR8	A194-GR8	A194-GR8
16	1	Gland Lock Washer	300SS	300SS	300SS	300SS
17	1	Bracket Bolts	A574 GR5	A574 GR5	A574 GR5	A574 GR5
18	1	Bracket Lock Washer	Carbon Steel	Carbon Steel	Carbon Steel	Carbon Steel
19	1	Stem Packing (Anti-Extrusion)	Grafoil®	Grafoil®	Grafoil®	Grafoil®
21	1	Spring	Inconel® 718	Inconel® 718	Inconel® 718	Inconel® 718
22	1	Body Gasket	316/Grafoil® Filled	316/Grafoil® Filled	316/Grafoil® Filled	316/Grafoil® Filled
23	2	Mounting Bracket Pin	Carbon Steel	Carbon Steel	Carbon Steel	Carbon Steel

Note: We reserve the right to change materials and specifications.

PRV Pressure Relief Valve

Feature & Applications

PBV® PRV

Pneumatic Actuated Pressure Relieving Valve for the first line of defense in controlling excessive system pressure buildup and protecting your safety relief valves from frequent opening.

- Calculated Bore Size
- 2" - 4" Nominal Pipe Size
- 150 - 4500 ANSI Class
- Available in SW, BW, FLG and NPT Ends
- Materials: A105, F22, F91, 316SS and Others Upon Request

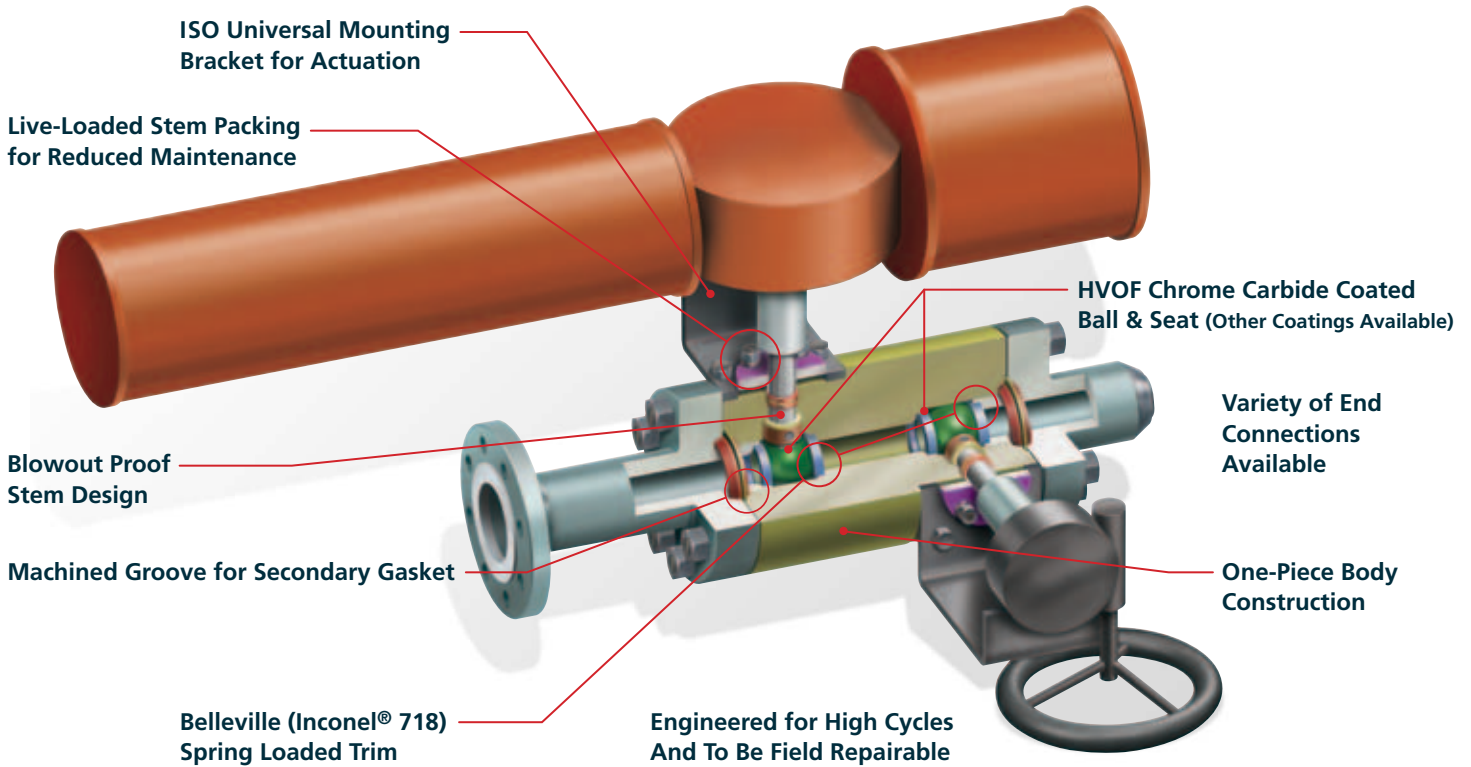

Engineering Data

Due to varying conditions and situations, each plan will have different materials, endcaps, etc. Dimensions will vary. Consult with factory for more information and verification when ordering.

PBV® Z1 Unibody Power Valve & Z2 Two-Piece Industrial Valve

Engineering Data

The C_v for valves indicates the flow capacity of the valve. C_v by definition is the volume of water in gallons per minute at 60°F that will flow through a given element with a pressure drop of 1 psig.

Series Z1 • Flow Coefficients (C_v)

Valve Size (in.)	Bore Size (in.) / Pipe Schedule													
	.65		1.00		1.40		1.75		2.00		2.50		3.05	
	80	160	80	160	80	160	80	160	80	160	80	160	80	160
1/2	22	22	—	—	—	—	—	—	—	—	—	—	—	—
3/4	32	40	—	—	—	—	—	—	—	—	—	—	—	—
1	31	26	103	74	—	—	—	—	—	—	—	—	—	—
1 1/2	15	16	48	56	155	212	—	—	—	—	—	—	—	—
2	14	15	40	46	105	135	264	375	466	347	—	—	—	—
2 1/2	—	—	36	37	86	94	170	208	304	400	—	—	—	—
3	—	—	28	29	75	80	135	150	202	234	481	655	—	—
4	—	—	—	—	56	58	115	120	160	172	296	342	588	785

Note: For other pipe sizes not in the chart, please contact factory.

Series Z2 • Flow Coefficients (C_v)

Valve Size (in.)	Flow Coefficients (C_v) Rating					
	Class 150	Class 300	Class 600	Class 900	Class 1500	Class 2500
1/2	26	26	26	26	26	20
3/4	62	62	62	52	52	33
1 x 1 1/2	8	8	8	9	9	10
1	114	114	114	84	84	61
1 1/2 x 1	40	40	40	45	45	70
1 1/2	270	270	270	223	223	145
2 x 1 1/2	105	105	105	120	120	270
2	500	500	500	432	432	270
3 x 2	159	159	159	168	177	286
3	1175	1175	1175	1070	978	640
4 x 3	427	427	427	454	528	640
4	2160	2160	2160	2013	1748	1070
6 x 4	787	787	787	830	916	1515
6	5076	5076	5076	4641	4018	2602
8 x 6	1724	1724	2161	2376	2815	—
8	9300	9300	8985	8120	7022	4641
10 x 8	4250	4250	4502	4992	6246	6622
10	14,865	14,865	14,095	12,966	11,228	7560
12 x 10	7348	7348	7776	9268	12,411	—
12	21,799	21,799	20,857	18,578	16,044	10,880
14 x 12	13,793	13,793	15,502	19,581	—	—
16 x 14	19,916	19,916	23,040	30,125	—	—
18 x 16	23,588	25,508	30,887	39,857	—	—
20 x 18	36,010	38,269	47,203	—	—	—
24 x 20	32,665	33,972	39,620	48,573	—	—

Note: I.D. of valve size is based on ASME B16.34 Annex A. Please contact factory for additional valve sizes.

PBV® Z1 Unibody Power Valve & Z2 Two-Piece Industrial Valve

Engineering Data

Relationship Between Nominal Pipe Size and Inside Diameter

The Table below is based on the dimensions given in B16.34 dimensional tables as "Inside Diameter of Fitting." The valves above nominal pipe size 24" for the lower pressure classes and above nominal pipe size 12" for Class 2500 are obtained by linear extrapolation.

Nominal Pipe Size (in.)	Inside Diameter (in.)						Class 2500
	Class 150	Class 300	Class 400	Class 600	Class 900	Class 1500	
1/2	0.50	0.50	0.50	0.50	0.50	0.50	0.44
3/4	0.75	0.75	0.75	0.75	0.69	0.69	0.56
1	1.00	1.00	1.00	1.00	0.87	0.87	0.75
1 1/4	1.25	1.25	1.25	1.25	1.12	1.12	1.00
1 1/2	1.50	1.50	1.50	1.50	1.37	1.37	1.12
2	2.00	2.00	2.00	2.00	1.87	1.87	1.50
2 1/2	2.50	2.50	2.50	2.50	2.25	2.25	1.87
3	3.00	3.00	3.00	3.00	2.87	2.75	2.25
4	4.00	4.00	4.00	4.00	3.87	3.62	2.87
5	5.00	5.00	5.00	5.00	4.75	4.37	3.62
6	6.00	6.00	6.00	6.00	5.75	5.37	4.37
8	8.00	8.00	8.00	7.87	7.50	7.00	5.75
10	10.00	10.00	10.00	9.75	9.37	8.75	7.25
12	12.00	12.00	12.00	11.75	11.12	10.37	8.62
14	13.25	13.25	13.12	12.87	12.25	11.37	9.50
16	15.25	15.25	15.00	14.75	14.00	13.00	10.87
18	17.25	17.00	17.00	16.50	15.75	14.62	12.25
20	19.25	19.00	18.87	18.25	17.50	16.37	13.50
22	21.25	21.00	20.75	20.12	19.25	18.00	14.87
24	23.25	23.00	22.62	22.00	21.00	19.62	16.25

Note: The information above is a nonmandatory part of ASME B16.34-1996 and is provided for informational purposes only. The information above is calculated for flanged end connections.

Pipe Schedule & Wall Thickness Chart • Formula: $NOD - (2 \times WT) = ID$

Nominal Pipe Size (in.)	OD (in.)	Pipe Schedule/Wall Thickness (in.)															
		5s	5	10s	10	20	30	40s & Std.	40	60	80s & E.H.	80	100	120	140	160	Double E.H.
1/2	.840	.065	.065	.083	.083			.109	.109		.147	.147				.187	.294
3/4	1.050	.065	.065	.083	.083			.113	.113		.154	.154				.218	.308
1	1.315	.065	.065	.109	.109			.133	.133		.179	.179				.250	.358
1 1/4	1.660	.065	.065	.109	.109			.140	.140		.191	.191				.250	.382
1 1/2	1.900	.065	.065	.109	.109			.145	.145		.200	.200				.281	.400
2	2.375	.065	.065	.109	.109			.154	.154		.218	.218				.343	.436
2 1/2	2.875	.083	.083	.120	.120			.203	.203		.276	.276				.375	.552
3	3.500	.083	.083	.120	.120			.216	.216		.300	.300				.437	.600
3 1/2	4.000	.083	.083	.120	.120			.226	.226		.318	.318					.636
4	4.500	.083	.083	.120	.120			.237	.237	.281	.337	.337		.437		.531	.674
4 1/2	5.000							.247			.355						.710
5	5.563	.109	.109	.134	.134			.258	.258		.375	.375		.500		.625	.750
6	6.625	.109	.109	.134	.134			.280	.280		.432	.432		.562		.718	.864
7	7.625							.301			.500						.875
8	8.625	.109	.109	.148	.148	.250	.277	.322	.322	.406	.500	.500	.593	.718	.812	.906	.875
9	9.625							.342			.500						
10	10.750	.134	.134	.165	.165	.250	.307	.365	.365	.500	.500	.593	.718	.843	1.000	1.125	
11	11.750							.375			.500						
12	12.750	.156	.165	.180	.180	.250	.330	.375	.406	.562	.500	.687	.843	1.000	1.125	1.312	
14	14.000	.156		.188	.250	.312	.375	.375	.437	.593	.500	.750	.937	1.093	1.250	1.406	
16	16.000	.165		.188	.250	.312	.375	.375	.500	.656	.500	.843	1.031	1.218	1.437	1.593	
18	18.000	.165		.188	.250	.312	.437	.375	.562	.750	.500	.937	1.156	1.375	1.562	1.781	
20	20.000	.188		.218	.250	.375	.500	.375	.593	.812	.500	1.031	1.280	1.500	1.750	1.968	
24	24.000	.218		.250	.250	.375	.562	.375	.687	.968	.500	1.218	1.531	1.812	2.062	2.343	

Our goal is to become the leading provider of mission critical oilfield products and related services in terms of customer satisfaction, safety and financial performance.

Our experienced management team and employees are dedicated to solving our customers' problems. We invest in long term relationships and cooperate on product development with our clients, we consider them our partners.

OUR CORE VALUES

Integrity: In everything we do, in every interaction, both internally and externally, we strive to operate with the upmost integrity and mutual respect.

Long-term view: We are building our company for the long-term, a company that we can be proud of.

Open communication: We believe partnerships with our customers and co-workers must be based on trust, professionalism and transparency.

Customer focused: Our products enhance our customer's performance and we listen to their needs and work with them to solve their challenges.

Good place to work: We are committed to creating a workplace that fosters innovation, teamwork and pride. Every team member is integral to our success and is treated equally and fairly.

No one gets hurt: The safety of our employees and customers is our first priority coupled with a healthy respect for the environment.

For more information about our products and full Terms & Conditions please visit www.f-e-t.com.



12735 Dairy Ashford Road
Stafford, Texas 77477
281.637.2000 [m] 800.256.6193 [tf] 281.340.5499 [f]
www.f-e-t.com